

Descend-
ing
windows.

The vertical highlight

The new descending window extends the air-lux product portfolio with an impressive new way of opening. The complete width of the descending window can be opened and the whole window unit is lowered into the ground. The advantage over sliding units: no fixed elements needed for the window to slide in front of.

Sealing with air –
the air-lux sealing concept

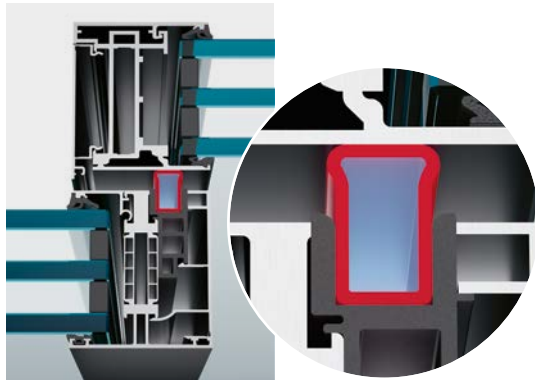

Active

With the press of a button, air is introduced into the frame. This closes the gap between the slider and the fixed frame, creating a perfect seal.

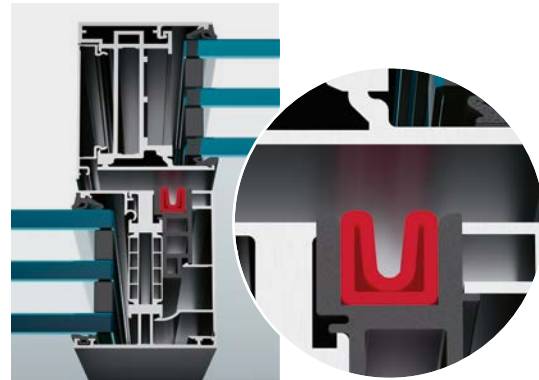

Inactive

To open the unit, the button is pressed a second time. The air is released and the seal retracts to its original concave profile.

Completely retractable: 100% impermeability.

The new descending window also impresses with its unique air-lux pneumatic sealing system. The continuous, inflatable ring seals match the movable pane element and close the gap between the pane and the fixed components perfectly, providing guaranteed 100% impermeability against driving rain, wind and noise.

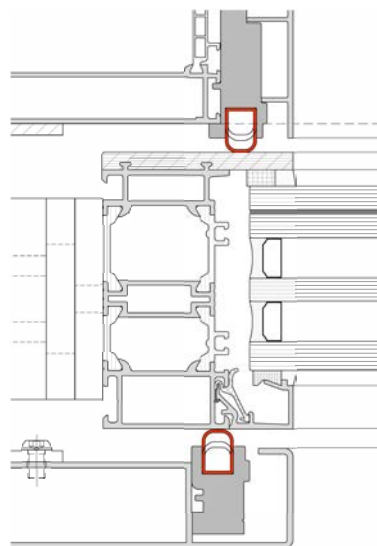

Horizontal cross-section detail

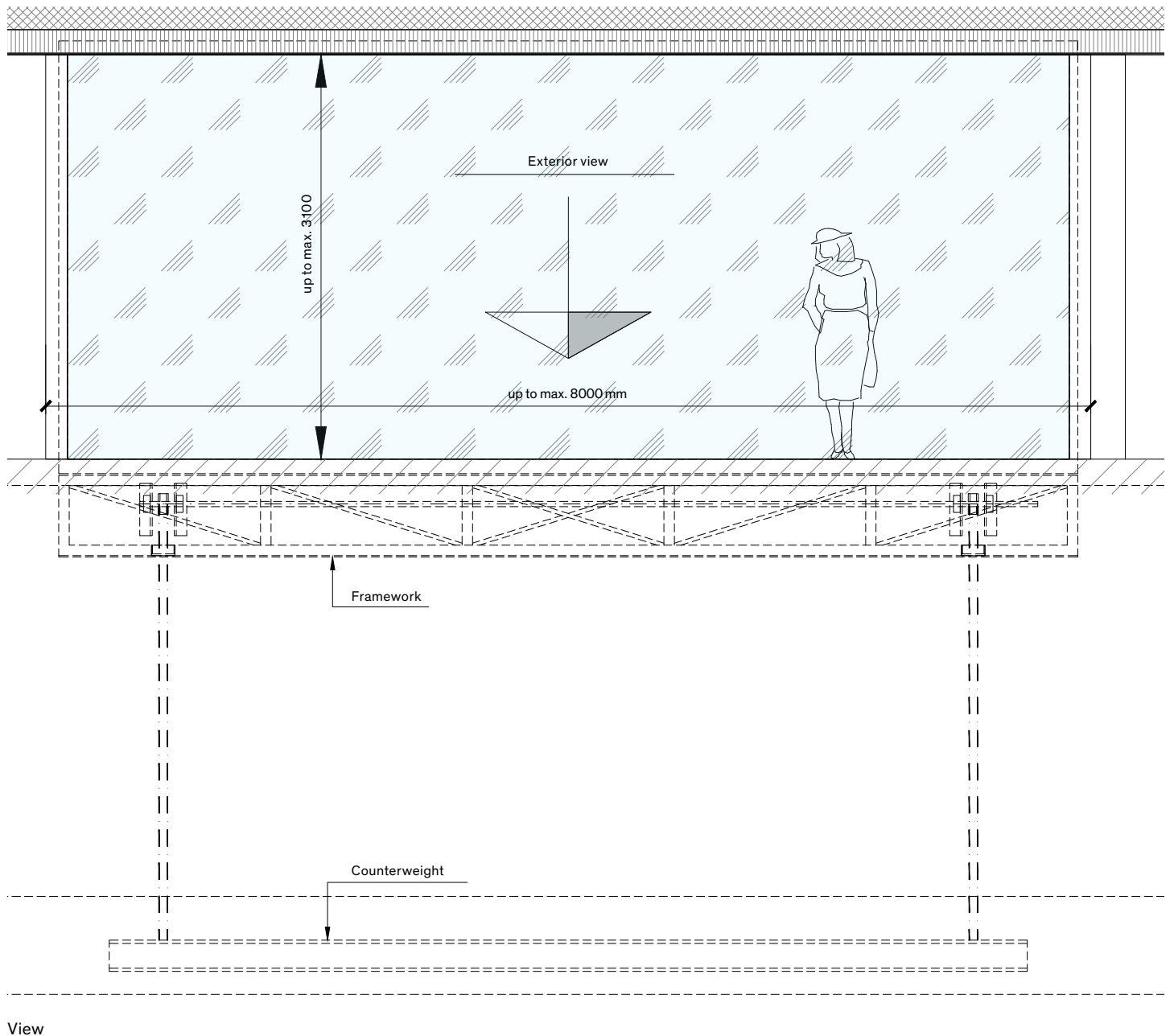

Up to 25 m² window area

Big is best – and this is also true for descending windows. The larger the achievable descending window, the more impressive the effect when open. The maximum window area is 25 m². There is no weight limit. Glass to a thickness of 60 mm can be installed, including bullet-proof safety glass.

Perfectly balanced

The descending window is located on a stable support mechanism connected to a counterweight that balances the descending window perfectly. The moving parts are raised and lowered silently by means of an electric drive. In the event of a power cut, the descending window can be closed by hand from the technical area.

Comfortable operation, maximum security

The descending window is operated by a button with a dead man's control and visual monitoring of the movement. Fully automatic control is also available if desired, whereby safety is guaranteed by radar or infrared.

The air-lux descending windows are manufactured and installed in compliance with the appropriate machine directives. Personal protection is therefore guaranteed at all times – whether in the operation of the descending window, during a power cut or in severe weather conditions.

Technical area

As the descending window disappears completely into the ground, enough space beneath the glazing must be available to accommodate it when open. This technical area includes the control, motor, drive shaft and the counterweight, and must be accessible for maintenance work. The dimensions of the technical area are determined and logged by air-lux. Rain water is collected in a concealed channel and drained away through a drainage opening.

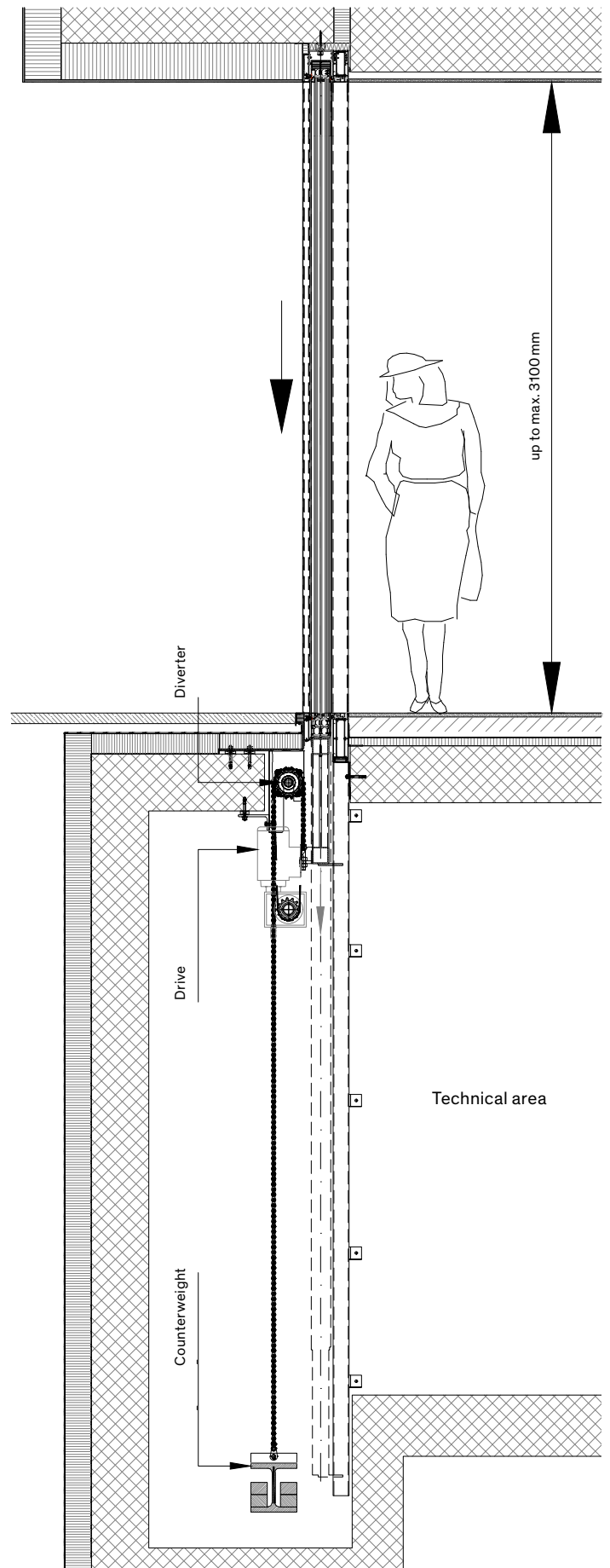

Vertical cross-section



Descending windows in various positions



10 Year Guarantee

air-lux descending windows are manufactured from high-quality aluminium profiles and materials in Switzerland. The finishing on the robust yet elegant frames meets the highest quality standards. air-lux is therefore able to guarantee perfect operation and offer a 10 Year Guarantee on the seals, framework and fittings. Our service team also provides 24-hour support for air-lux customers.

